



RETAILER'S GUIDE TO IMPLEMENTING

# EFFECTIVE BICYCLE PARKING

---

Attract Customers to Your Doorstep  
Accommodate More Customers in Less Space  
Eliminate Hazards and Clutter  
Promote Community Goodwill



# Introduction

**PROVIDING EFFECTIVE BICYCLE PARKING** makes good business sense. Implementing effective bicycle parking facilities attracts customers directly to your doorstep. It prevents hazards and clutter, and it helps make the retail neighborhood attractive. Where car parking is tight, every customer arriving on a bike leaves a car parking space free for someone else.

And people are rediscovering the bicycle for trips to the store. By riding a bike instead of driving a car, they can enjoy fresh air and exercise, and the convenience of avoiding gridlock.

Customers arriving by bike, just like customers arriving by car, need a suitable and convenient place to park their vehicles. Bicyclist customers want to be confident that their bikes will be secure from theft or damage while they shop.

All too often, bike parking facilities, when they exist, suffer from an outdated bike rack design or an unsuitable location. They may even be completely unusable for secure bike parking. In such situations, bicyclist customers will either improvise, by parking next to the nearest fixed object, or they will simply take their business elsewhere.

Fortunately, with a bit of attention and a minimal investment, excellent bike parking can be implemented in any retail location. This document provides all the information (plus some key pointers) that a retailer needs for implementing effective bicycle parking--and attract loyal bicyclist customers.

It is hoped that this information will contribute to better bike parking, help make our local retail neighborhoods vibrant, and encourage more Americans to shop, dine, play, and do errands by bicycle.

## ACKNOWLEDGMENTS

This document was created as part of Shop by Bike, a volunteer project of the Bicycle Alliance of Washington, supported by City of Seattle CarSmart Communities Challenge Grants, 2001-02. Coordinator/editor: Emily Allen. Co-coordinator (and spokesmodel): Chris King. Text: Emily Allen, Rebecca Slivka, Evan Lewis. Shop by Bike logo: Chicagoland Bicycle Federation and Chicago DOT. Photos: Emily Allen, Rebecca Slivka, Linda Schwartz, Jennifer Quesinberry, Mary Catherine Snyder. Volunteers: Rebecca Slivka, Evan Lewis, Linda Schwartz, Jennifer Quesinberry, Mary Catherine Snyder, Shannon Markley, Pam Mandel, Aaron Goss. Thank yous to: Tom Bertulis, Amy Carlson, Barbara Culp, Peter Dewey, Gary Goldbaum, Jemae Hoffman, Ken Jacobsen, Peter Lagerwey, Anne Vernez Moudon, Bill Nye, Randy Wiger, Gregg's Cycles, REI, and all the volunteers. Please do freely copy, share and distribute this document: Adobe Acrobat (.pdf) file available at [www.bicyclealliance.org](http://www.bicyclealliance.org) or email [emilyallen@aol.com](mailto:emilyallen@aol.com).

## CONTENTS

Introduction	2
Bike Racks: Fundamentals	3
Bike Racks: Problems to Avoid	4
Design Specifications	5
Locating Bike Parking: Basics	6
Location & Layout: More Pointers	7
Summary: The 12 Bike Parking Essentials	8



# Bike Racks: Fundamentals

## 1 BIKE RACK SUPPORTS FRAME

A bike rack should support the bicycle frame in two places, since most bikes aren't freestanding. Inverted-U racks work well (see box). Avoid outdated bike racks that only support the bicycle at the wheel, as these can damage wheels, and are not suitable for secure locking. The popular ribbon or wave-type rack, when used as designed, only supports a bicycle in one place, leaving bikes susceptible to falling down or being knocked over.



*This type of bike rack, shaped like a giant staple with a crossbar, supports a bike frame well.*

*The popular wave-type rack can fully support a bicycle only when used "broadside." When used as designed, bikes are susceptible to falling down.*



*Adequately spaced bike racks, with 30 to 36 inches between racks, allow obstacle-free access to bike parking spaces.*



*Many manufactured bike racks force bicycle handlebars (24") to overlap and crowd each other.*

## 2 SPACES OF ADEQUATE WIDTH

Most manufacturers still sell outdated bike racks that do not accommodate the very common mountain-style handlebars (typical width 24"). They often overstate the capacity their bike racks provide. Plan for at least 2 feet wide by 6 feet long per bike parking space, reflecting bikes' actual size. Multiple side-to-side bike racks should be spaced at least 30 inches apart. End-to-end racks, as along a sidewalk, should be at least 5 feet apart. See page 5 for layout requirements.

## 3 ACCOMMODATES VARIOUS LOCKS

A bike rack should be able to accommodate U-locks, cable locks, and chains, and allow both the bicycle frame and wheels to be secured to the bike rack. The geometry of the bike rack should make it easy to lock to. Also, pipe used to make bike racks shouldn't be too thick (outer diameter of 2 inches max), so a lock can easily get around both the rack and the bike.



*U-lock and cable lock.*

## 4 SIMPLE AND DURABLE

A bike rack should have no moving parts. It should be designed to be simple to use with any style or size of bike. It should also be sturdy and able to be solidly affixed to the pavement. The surface coating should be maintenance-free, as well as corrosion- and impact-resistant, and non-damaging to bikes' finish. See page 5 for complete bike rack specifications.

### GOOD DESIGN: INVERTED-U RACK

The inverted-U bike rack is now the preferred design for quality bike parking. Several municipalities now require it for bike parking. The inverted U offers an aesthetically appealing design while fulfilling all the functional requirements of a good bike rack. It is also economical and can be simply made from standard pipe by a metal fabricator. See page 5 for complete specifications for fabricating inverted-U racks, as well as contact information for manufacturers.



*The inverted-U bike rack, whether as stand-alone units or on rails with multiple Us, make for excellent bike parking when the inverted Us are spaced at least 30 inches apart. Two bikes can use each inverted U.*

# Bike Racks: Problems to Avoid

## AVOID THE DISH-DRIER, OR FENCE RACK

This old grade-school bike rack also only supports the bicycle wheel, and can damage the wheel if the bike is jostled or falls down. Used as designed, it is not suitable for secure locking. Generally, the only places to lock the bicycle frame to are the two ends of the dish-drier rack. Thus, its real capacity is generally two bicycles, no matter how big and space-consuming it is. Sometimes it is used broadside, again, with severely diminished capacity compared to manufacturer's claims. (Occasionally, bicyclists will lift the front end of the bike over the top bar of the dish-drier rack in order to lock securely; not only is this cumbersome, but it can damage the bike.)



*Avoid these old, grade-school style bike racks! Their capacity is severely diminished by their poor design -- and they can also damage bikes.*

## AVOID THE WHEEL-BENDER

This outdated bike rack supports only the bicycle wheel. It can damage the wheel if the bike is jostled or falls down. It is also totally unsuitable for secure locking.



*Avoid this outdated, wheel-bending bike rack! It is impossible to lock a bicycle securely to it.*

## BEWARE OF EXAGGERATED CAPACITY CLAIMS

The popular wave-style (or ribbon) bike rack, at left below, has several limitations. Manufacturers' claims about the number of bikes these racks will realistically hold are often exaggerated. Actual use is generally one bike per down-curve. Also, this type of rack does not support the bike frame well when used as designed. When this rack is used "broadside," which better supports the bike frame, the capacity is reduced even further, as seen below.

Manufacturers of other rack styles may also exaggerate capacity. The spaces on their bike racks are often too narrow because they were designed for older, drop-style handlebars (see the clashing handlebars in the middle picture below). Mountain-style handlebars, now the most prevalent style, are typically 24 inches across. Plan for each bike parking space to be at least 24 inches wide.



*Wave-style (or ribbon) bike racks typically have exaggerated capacity claims and poor support for the bike frame, unless used "broadside" as seen at lower left.*



*Many manufactured bike racks force bicycle handlebars (24" wide) to overlap or crowd each other. Adequate space is also needed for bike bags (panniers), especially when they're being filled with purchases!*

# Design Specifications

## SPECS FOR INVERTED-U RACK

**Height:** 36" (range 32-36"); **Width:** 24" (range 18-24")  
**Shape:** Single continuous bend (internal radius 10"); one-piece construction with straight parallel legs.  
**Pipe size:** 1.9" outer diam., 1.5" inner diam. (ASTM A53 Sched. 40 nominal size 1 1/2" steel pipe, 0.145" wall thickness); total length of about 86".  
**Anchor flanges:** Two 6" diam. circles (3/16" thickness) with three holes (7/16" diam., 1" from outer edge, set at 120-degree angles), flush-mount welded to base of each leg.  
**Bolts:** Secure anchor bolts for affixing to concrete.  
**Surface:** Hot-dipped galvanized after fabrication; hand-filed to remove galvanizing flash. **Coating:** Electrostatically applied polyester (TGIC) powder coat paint (6-8 mils), or PVC coating (15 mils).  
**Rails for multi-U racks:** 4" wide, sufficient length to allow 30" between inverted Us.

## MANUFACTURERS

### Specializing in the Inverted U:

**Cycle-Safe** (One-Bend Rack), [www.cycle-safe.com](http://www.cycle-safe.com), 1-888-950-6531, [cyclesafe@aol.com](mailto:cyclesafe@aol.com).

**Function First Bike Security** (The Bike Rib), [www.bikerack.com](http://www.bikerack.com), 1-888-BIKERIB (1-888-245-3742), [bikerib@qwest.net](mailto:bikerib@qwest.net).

**Also:** Dero (Hoop Rack), [www.dero.com](http://www.dero.com);  
 Creative Pipe (SU, WU racks), [www.creativepipe.com](http://www.creativepipe.com);  
 Graber (Bike Dock), [www.graberparking.com](http://www.graberparking.com);  
 Huntco (HP Rack), [www.huntco.com](http://www.huntco.com);  
 Madrax (U-Two Rack), [www.madrax.com](http://www.madrax.com).

**Or use your local metal fabricator** and the inverted-U rack specifications at left. See the Yellow Pages under Metal Fabrication. *Note:* This is not a complete list, and no endorsement is implied of any company.

## LAYOUT AND SPACE REQUIREMENTS FOR BICYCLE PARKING

**Side-by-side rack placement:** Racks, which hold two bikes each, must be 30" apart from one another, and end racks must have 24" clearance to the sides from walls or other objects. In addition to space for bikes, an aisle is needed to that bikes can independently access the area. The layout shown at left below is 9 x 12 feet.

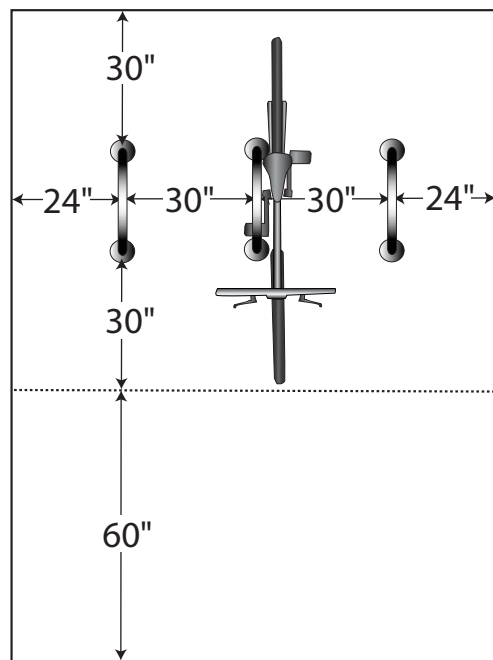

**End-to-end (as along a sidewalk or wall):** If racks are placed end-to-end along a wall, an access aisle is needed, and racks should be placed 7.5 feet (90 inches) apart. If along a sidewalk, allow at least 5 feet between racks; racks on the sidewalk should be set back an additional foot (3 feet total) from the curb, away from car doors. The layout shown at right is 4 x 16.5 feet.

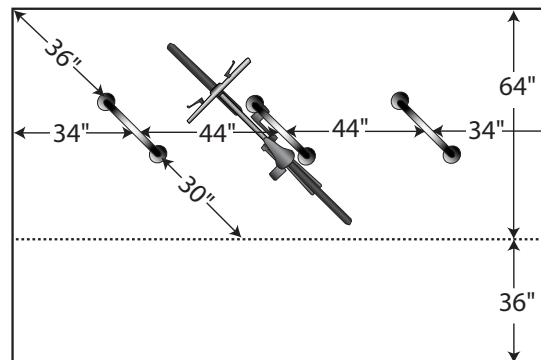

**Angle layout (as in car parking stall):** If a car parking stall is to be used for bike parking, it must be as close as possible to the store entrance. Bollards or other guarding is needed to protect bikes from cars.

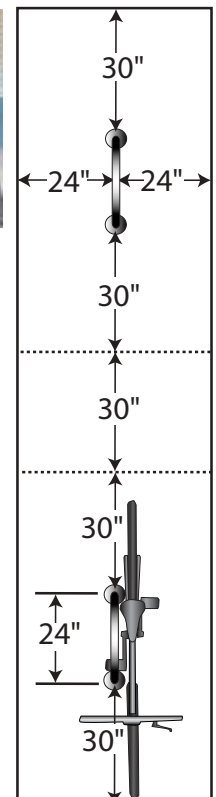

# Locating Bike Parking: Basics

## 1 SAFE AND EASY ACCESS

Bike parking should be reachable without conflict with automobiles or with pedestrian thoroughfares. Access ways must not require bicyclists to traverse a parking lot to reach bike racks, since the many backing and turning maneuvers of cars are hazardous for bikes. Stairs and curbs, obstacles for bikes, should be avoided.



## 2 SUFFICIENT SURROUNDING SPACE

Plan with the bikes in mind, not empty racks. Bikes are typically 2 feet wide by 6 feet long. Also allow room to maneuver in and out. It is very important to maintain at least a 2-foot clearance to all sides from walls and other objects. Refer to page 5 for layout requirements.



## 3 VISIBLE AND CONVENIENT

Locating bicycle parking in a highly visible and highly convenient spot is critical. Bike racks should be located as close as possible to entrances. If racks are around the side or back, or in a garage, they won't be seen or used. Customers will improvise, locking to any fixed object.



## 4 SECURELY IN VIEW

The security of customers' bikes from theft and damage is greatly enhanced by locating bicycle parking in plain view of passers-by and of windows. For employees' all-day use, more physical security is needed (bike room, cage, or lockers). Provide for both types of bike parking, short-term (customer) and long-term (employee/commuter).



## 5 ON A LEVEL EVEN SURFACE

Bicycles, not being freestanding, are difficult to park and lock when on a sloped surface, especially when bike bags are full. On a slope, bikes can roll, and on a cross-slope, they can tip. An uneven, cracked, or puddly area can also be a problem. The bike parking area should be level and even.



## 6 AFFIXED TO THE PAVEMENT

Bike racks should be solidly affixed to the pavement using tight, secure bolts or by setting in concrete. Bike racks should not tilt or wobble. Be sure bike racks cannot be hoisted in a way that allows bikes to be stolen.



## 7 ADEQUATELY LIT

If street lamps or outdoor building lighting doesn't illuminate the bike parking area, add appropriate lighting for ease of locking and unlocking bikes and stowing purchases--as well as for personal and bicycle security.

## 8 COVERED FROM WEATHER

Bicyclists appreciate cover from rain. Awnings should be adequate to cover bikes, not just empty racks. Overhangs should be sufficient to protect from blowing rain. Note: Retail customer bike parking should not be located in the depths of parking garages; all-day employee parking may be appropriate there, inside a bike cage or bike lockers (see box on page 7).



# Location & Layout: More Pointers

## AVOID PHYSICAL OBSTRUCTIONS...

Remember to plan bike parking with the bikes in mind, not empty racks. All styles of bike rack require several feet of clear space around the rack, free of obstructing objects including garbage cans, merchandise displays, walls, pillars, and shopping carts. A common problem, shown at right, is placing a ribbon-style rack too close to a wall; a 30" setback is needed. Remember to allow 2 feet by 6 feet for each parked bike, with a surrounding access zone of at least two feet clear on all sides. Some configurations require additional space for access (refer to page 5 for detailed layout requirements).



## ...AND TAKE CARE TO NOT CREATE FUNCTIONAL OBSTRUCTIONS

Establish a dedicated space for bicycle parking, and avoid creating functional obstructions. Don't locate bike racks in such a way that parked bikes would conflict with driveways, loading docks, disabled parking spaces, fire lanes, pedestrian walkways, or any other access way.



*Functional obstructions, such as a bike rack in a disabled access lane (left), bike parking jutting into fire lane (center), or bike parking in the way of pedestrians (right), should be avoided.*

## PARKING GARAGES: NOT GOOD FOR CUSTOMERS, POTENTIALLY GOOD FOR COMMUTERS

Parking garages, though covered, are often poorly suited for retail customer bicycle parking. Bike racks in garages lack convenience to entrances and visibility to passersby. Garages are often unsafe for bicyclists because of cars' semi-blind backing and turning movements, and because of personal security issues. Bike rack areas in garages can also become dumping grounds for shopping carts. Nonetheless, parking garages *can* be suitable for longer-term (all-day) commuter bike parking, if physically secure facilities such as a bike cage (with bike racks inside), or bike lockers, are installed.



# Summary: The 12 Bike Parking Essentials

## *Bike Rack Selection*

### 1 BIKE RACK SUPPORTS FRAME

A bike rack should support the bicycle frame in two places, since most bikes aren't freestanding. Avoid outdated bike racks that only support the bicycle at the wheel, as these can damage wheels, and are not suitable for secure locking.

### 2 SPACES OF ADEQUATE WIDTH

Most manufacturers still sell outdated bike racks that do not accommodate the very common mountain-style handlebars (24" width). They often overstate the actual capacity their bike racks provide. Plan spaces for bikes at 2 feet wide by 6 feet long, per space, reflecting bikes' actual size.

### 3 ACCOMMODATES VARIOUS LOCKS

A bike rack should be able to accommodate U-locks, cable locks, and chains, and allow both the bicycle frame and wheels to be secured to the bike rack.



### 4 SIMPLE AND DURABLE

A bike rack should have no moving parts. It should also be sturdy and have a maintenance-free coating that doesn't damage bikes.



## *Locating Bike Parking*

### 5 SAFE AND EASY ACCESS

Bike parking should be reachable without conflict with automobiles or with pedestrian thoroughfares. Access ways must not require bicyclists to traverse a parking lot to reach bike racks, as the many backing and turning movements of motor vehicles are hazardous for bikes. Stairs and curbs, obstacles for bikes, should be avoided.

### 6 SUFFICIENT SURROUNDING SPACE

Plan with the bikes in mind, not empty racks. Bikes are 2 feet wide by 6 feet long. Also allow room to maneuver in and out. Maintain at least a 2-foot clearance to all sides from all walls, poles, trash cans, and merchandise.

### 7 VISIBLE AND CONVENIENT

Locating bicycle parking in a highly visible and highly convenient spot is critical. Bike racks should be located as close as possible to entrances. If bike racks are around the side, at back, or in a garage, they won't be seen or used. Customers will improvise, locking to any nearby fixed object.

### 8 SECURELY IN VIEW

The security of bikes from theft and damage is greatly enhanced by locating bicycle parking in plain view of passers-by and of windows. Customers appreciate highly visible bike parking. For all-day use, as for employees, a higher level of physical security (bike room, cage, or lockers) is needed. Provide for both types of bike parking.



### 9 ON A LEVEL EVEN SURFACE

Bikes are hard to maneuver, lock and unlock on a sloped surface, especially when loaded with purchases. On a slope, they'll roll forward or back, and if there's a cross-slope, they will tend to tip. An uneven, cracked, or puddly area can also be a problem. The whole bike parking area should be level and even.

### 10 AFFIXED TO THE PAVEMENT

Bike racks should be solidly affixed to the pavement using tight, secure bolts or by setting in concrete. Bike racks should not tilt or wobble. Be sure bike racks cannot be hoisted to steal bikes.

### 11 ADEQUATELY LIT

If street lamps or outdoor building lighting don't illuminate the bike parking area, add appropriate lighting for ease of locking and unlocking bikes and stowing purchases--as well as for personal and bicycle security.

### 12 COVERED FROM WEATHER

Bicyclists appreciate cover from rain. Awnings should be adequate to cover bikes, not just empty racks. Overhangs should be sufficient to protect from blowing rain. Note: Retail customer bike parking should not be located in the depths of parking garages; all-day employee parking may be appropriate there, inside a bike cage or bike lockers.

